

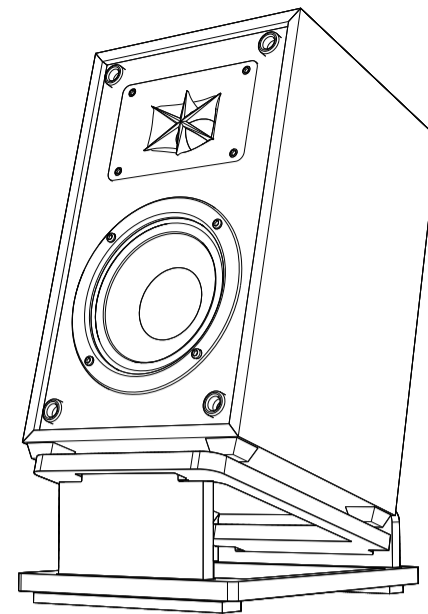

# Starfavor SS-02

## Bamboo Desktop Speaker

### Stands Owner's Manual



## Precautions

### PLEASE READ CAREFULLY BEFORE PROCEEDING

Keep the manual in a safe place for future reference

### Safety Information

- To reduce risk of internal damage or malfunction, never expose the unit to rain, moisture or excessive humidity. Never let any liquid spill on the unit.
- Never expose the unit to a temperature higher than 60°C (140°F).
- Never step over the unit or step on it with your full weight, this might cause permanent damages to the unit's structure.
- All servicing should be referred to qualified personnel only.

## Overview

The SS-02 Bamboo Desktop Speaker Stands are designed for 3 to 6.5-inch multimedia speakers, Hi-Fi speakers, and studio monitors, enhancing the listening experience through special acoustic design. The SS-02 uses high-strength special bamboo material, making the speaker stands more rigid and capable of supporting heavier speakers. The bamboo material also reduces vibrations, resulting in less bass loss. The bamboo stands, combined with a deep brown color, better align with the aesthetic preferences of high-end Hi-Fi equipment.

The 15° tilt design aligns with the usage habits of most desktop speaker users, directing the tweeters towards the ears to capture more high-frequency details, providing a wider soundstage and more accurate positioning in the music listening experience. The included EVA pads are suitable for speakers without EVA anti-slip pads on the bottom. Attaching the two EVA strips to the SS-02 reduces vibrations during playback, minimizing bass loss and achieving a more faithful listening experience.

Additionally, the SS-02 features a unique hollow design in the middle, reducing the contact area between the speaker and the stand, which further reduces vibration loss and enhances the listening experience.

- Premium Materials: Made from high-strength bamboo, the stands are more rigid and can support heavier speakers while reducing vibrations and bass loss.
- High-End Aesthetics: The deep brown bamboo design aligns with the aesthetic standards of high-end Hi-Fi equipment.
- 15° Tilt Design: This design caters to the usage habits of most desktop speaker users, enhancing high-frequency details and providing a wider soundstage and more accurate positioning.
- Included EVA Pads: Suitable for speakers without EVA anti-slip pads, reducing vibrations and bass loss during playback, thereby enhancing sound fidelity.
- Unique Hollow Design: Reduces the contact area between the speaker and the stand, further minimizing vibration loss and enhancing the listening experience.

## Setup

### Installation guide

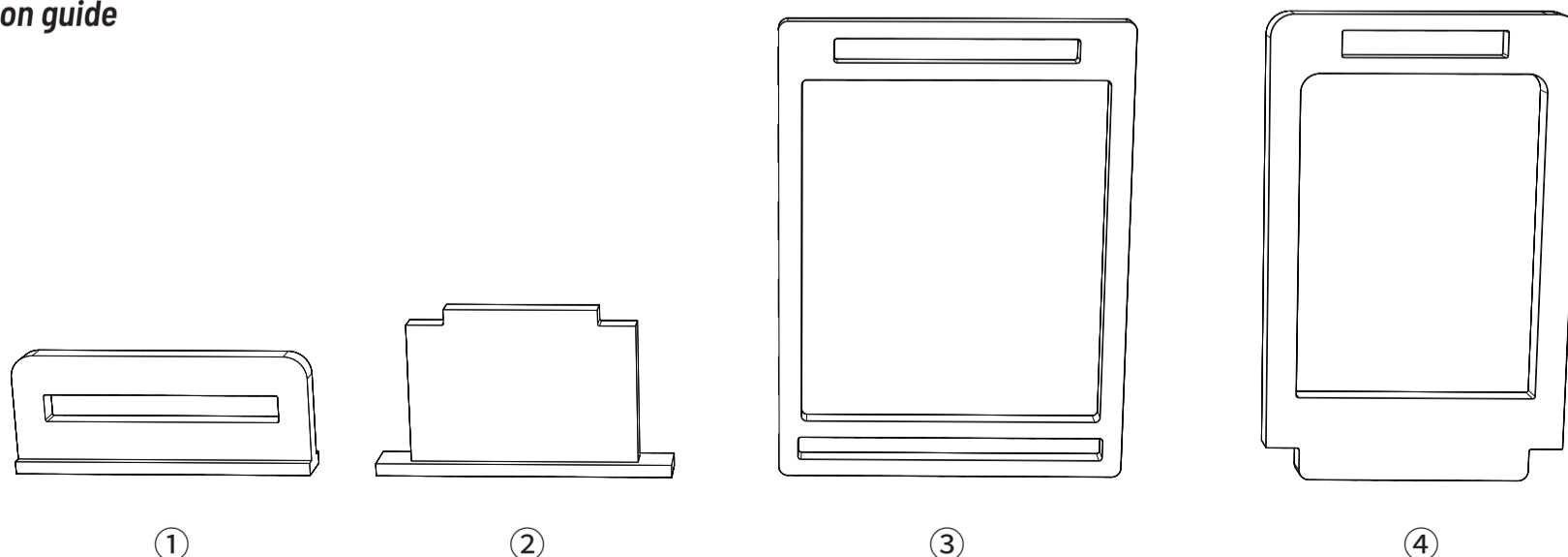

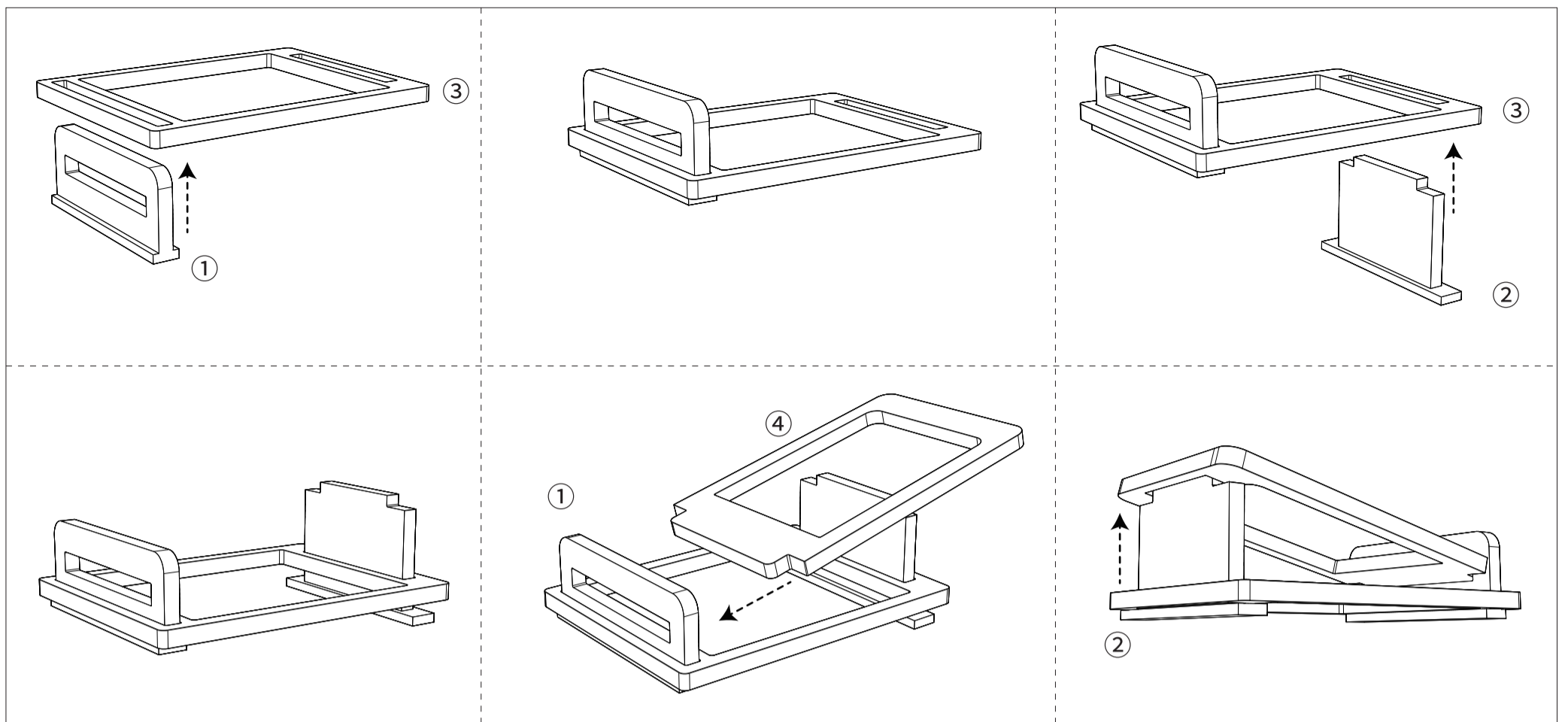

## Setup guide

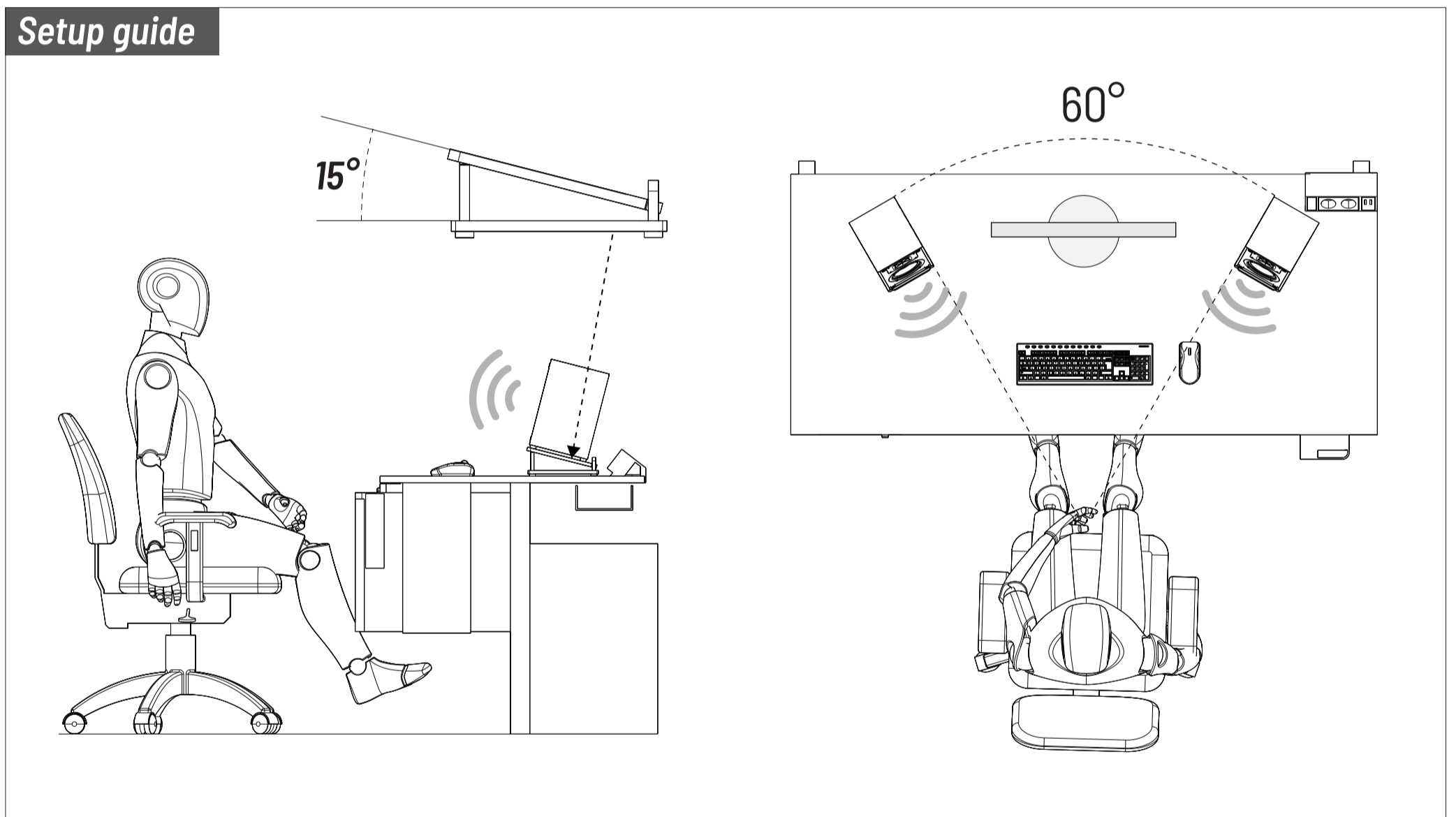

## Specification

<b>Material</b>	Bamboo
<b>Angle</b>	15°
<b>Max Load</b>	22lbs
<b>Weight</b>	250g (Single)
<b>Dimension</b>	200*148*79 mm
<b>Accessory</b>	EVA / Owner's Manual

\*Notes: Any specification's update will not be amended in this manual.